

ADJUSTABLE FLOOR DRAIN - EXTENDED RIM

862 SERIES

SPECIFICATION

Sioux Chief 862 Series coated cast iron adjustable floor drain with anchor flange, weep holes, clamping collar, adjustable round nickel-bronze top with extended rim and vandal resistant secured grate, 1/2" NPT trap primer (plugged) and bottom outlet. Designed in accordance with ASME A112.6.3

For use in non-traffic areas when an extended rim is needed for anti-flood and anti-splash drip pan is required.

MATERIALS

Drain body: cast iron
Clamping collar: cast iron
Head/strainer: nickel-bronze

LOAD RATING

Light-duty (< 2,000 lbs). Heel-resistant grate.

DIMENSIONS

A: Connection size (No-Hub)	2", 3", 4"	
B: Top diameter	7"	9-1/2"
C: Rim height	1.25"	1"
D: Strainer adjustment	2.13" - 3"	2.5" - 3"
Strainer free-area	15.8 in ²	31.0 in ²

ITEM # SUBMITTED	_____
JOB NAME	_____
LOCATION	_____
ENGINEER	_____
CONTRACTOR	_____
PO#	_____ TAG _____

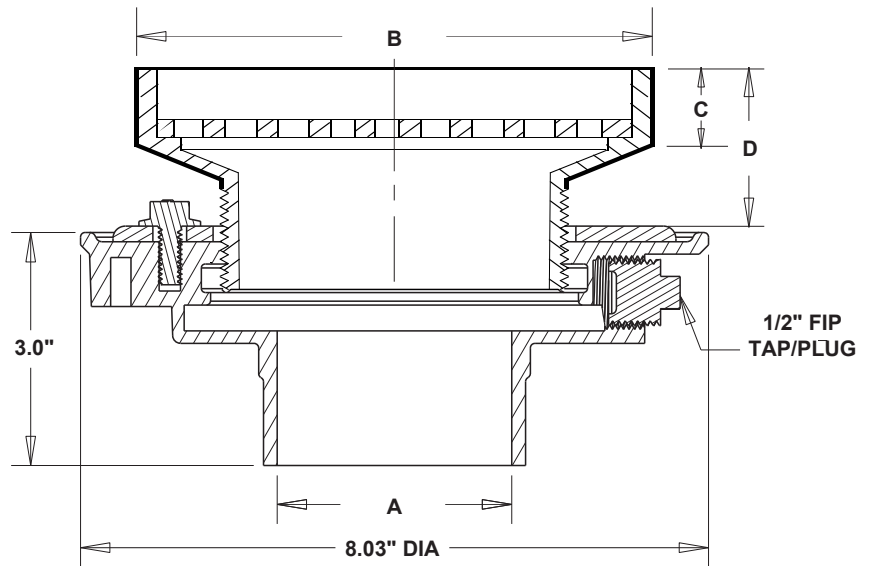

Create Item Number

862-ABCD

e.g. **862-237NREB:** Floor drain - 3" No-Hub connection, 7" round NB head/strainer with extended rim and debris bucket

CONNECTION TYPE A

- 2 = No-Hub outlet
- 6 = Push-Joint outlet

CONNECTION SIZE B

- 2 = 2"
- 3 = 3"
- 4 = 4"

STRAINER DIAMETER C

- 7NRE = 7" round
- 10NRE = 10" round

OPTIONS D

- B = Debris bucket
- E = Drain head extension adapter¹
- 9 = Side-outlet connection²

1: Cast iron - MIP x FIP thread | 2: For 3" and 4" No-Hub connection only