

TankBracket™

 Expansion Tank Support



Strong

18-gauge, galvanized steel is corrosion-resistant and provides safe, secure expansion tank installations

Nylon straps (included) keep tanks firmly in place, while the sturdy support base bears the weight of the tank

Prevents undue stress on threaded joints and other connections

Versatile

Wall-mount and tank-mount models available

Supports large (5-gal.) and small (2-gal.) expansion tanks, with connection nipple at top or bottom

Works with any water heater restraints, or seismic/safety straps up to 1.75" wide

 **Made in the USA**

Supply

Drainage

Support

Specialties

www.siouxchief.com

TAKE THE FIELD.



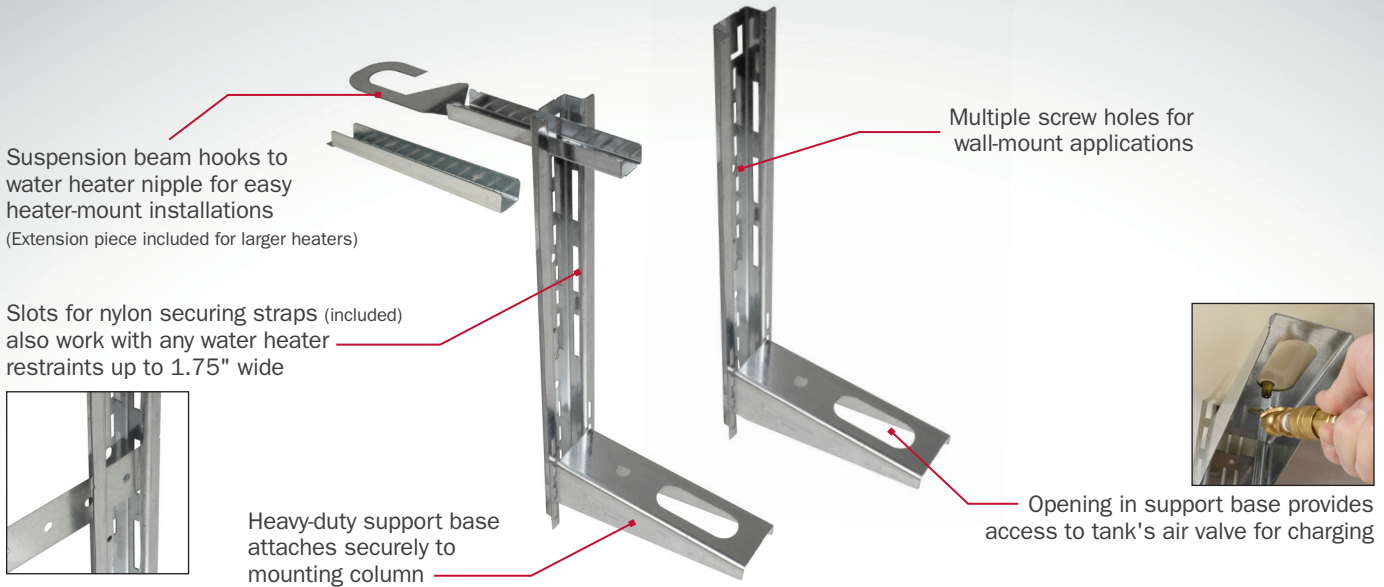

Attach the mounting column of the 2-pc. model using two or more screws (drive screws into studs) to support tank on an adjacent wall



Hook the suspension beam of the 3-pc. model to the water heater nipple to support tanks vertically against the side wall of the heater tank. (Use extension piece for larger heaters)



Support base allows tank to be installed with connection on bottom for applications where tank is above heater

598-022
(two-piece)

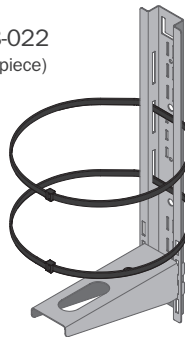

598-023
(three-piece)

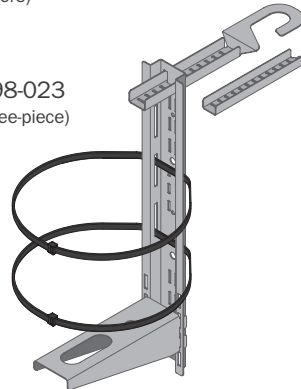

Buying Information

ITEM NO.	DESCRIPTION	PKG	MIN. QTY.	CASE QTY.
EXPANSION TANK SUPPORT				
598-022	2-Piece TankBracket™ with Nylon Straps (2) for Wall Mount	BI	10	10
598-023	3-Piece TankBracket™ with Nylon Straps (2) for Heater Mount	BI	10	10